

Controlled Reduction of Tertiary Amides to the Corresponding Alcohols, Aldehydes, or Amines Using Dialkylboranes and Aminoborohydride Reagents

Christopher L. Bailey, Alexander Y. Joh, Zefan Q. Hurley, Christopher L. Anderson, and Bakthan Singaram*

Department of Chemistry and Biochemistry, University of California, Santa Cruz, 1156 High Street, Santa Cruz, California 95064, United States

S Supporting Information

ABSTRACT: Dialkylboranes and aminoborohydrides are mild, selective reducing agents complementary to the commonly utilized amide reducing agents, such as lithium aluminum hydride (LiAlH_4) and diisobutylaluminum hydride (DIBAL) reagents. Tertiary amides were reduced using 1 or 2 equiv of various dialkylboranes. The reduction of tertiary amides required 2 equiv of 9-borabicyclo[3.3.1]nonane (9-BBN) for complete reduction to give the corresponding tertiary amines. One equivalent of sterically hindered disiamylborane reacts with tertiary amides to afford the corresponding aldehydes. Aminoborohydrides are powerful and selective reducing agents for the reduction of tertiary amides. Lithium dimethylaminoborohydride and lithium diisopropylaminoborohydride are prepared from *n*-butyllithium and the corresponding amine-borane. Chloromagnesium dimethylaminoborohydride ($\text{ClMg}^+[\text{H}_3\text{B-NMe}_2]^-$, MgAB) is prepared by the reaction of dimethylamine-borane with methylmagnesium chloride. Solutions of aminoborohydride reduce aliphatic, aromatic, and heteroaromatic tertiary amides to give the corresponding alcohol, amine, or aldehyde depending on the steric requirement of the tertiary amide and the aminoborohydride used.

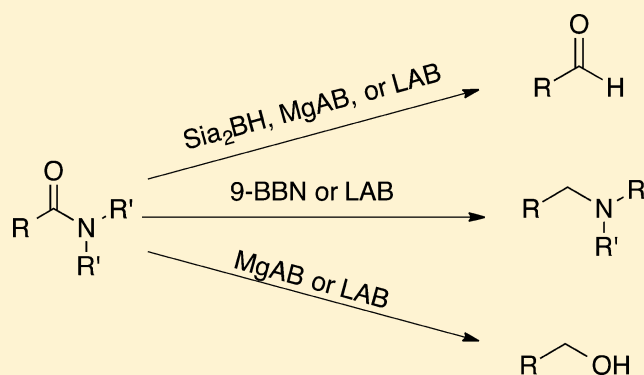

1. INTRODUCTION

Reduction of tertiary amides with metal hydride reagents to the corresponding alcohols or amines is known.¹ Sodium borohydride (NaBH_4) reduces amides to alcohols at elevated temperatures.² The partial reduction of amides to the corresponding aldehydes represents a challenge: several methods have been reported in the literature. Controlling the reduction of amides to aldehydes often relies on substrate-specific conditions to achieve a high yield of the aldehyde.³ The outcome of the reaction is dependent upon the nature of the substituent on the amide nitrogen atom, with bulkier substituents affording higher yields of aldehydes.^{4,5} In most cases, this transformation is carried out with lithium aluminum hydride (LiAlH_4),⁶ diisobutylaluminum hydride (DIBAL),⁷ and their derivatives.⁸ Generally, the reduction of amides to aldehydes with commercially available metal hydride sources results in poor yields of the aldehydes.⁹ These methods suffer from such drawbacks as requiring cryogenic reaction conditions and exothermic workup. Current methods lead to over-reduction to amines or alcohols. Borohydrides reduce tertiary amides, but they are not as reactive as aluminum hydrides.¹⁰

One synthetic strategy to prevent over-reduction employs specialized amide derivatives, such as *N*-acylcarbazoles,¹¹

morpholine amides,¹² and *N*-methoxy-*N*-methylamides (Weinreb amides).⁵ Weinreb amides are prepared easily from carboxylic acids¹³ and their derivatives.¹⁴ In a recent report, Weinreb amides were accessed through nucleophilic attack of *N*-methoxy-*N*-methylpyrrolicarboxamide.¹⁵ Controlled reduction of amides to aldehydes typically uses strong reducing agents, such as DIBAL or LiAlH_4 , and cryogenic reaction conditions.¹⁶

Recent work on the reduction of amides to aldehydes uses titanium and zirconium hydrides.¹⁷ Georg reported a promising reduction of tertiary amides, including Weinreb amides, to aldehydes using Schwartz reagent, $\text{Cp}_2\text{Zr(H)Cl}$.^{18,19} The methodology is noteworthy in that the reductions are carried out at room temperature, affording the product within 30 min. Although the Schwartz reagent is commercially available, it is expensive and poses challenges for long-term storage due to its sensitivity to air, light, and moisture.²⁰ It is highly desirable to develop a stable reducing agent based on readily available metals, capable of controlled room temperature reduction of amides.

Received: February 6, 2016

Published: April 1, 2016

We have reported the reduction of both aliphatic and aromatic amides with dialkylboranes and lithium aminoborohydrides (LAB reagents). The product of the reduction depends on both the nature and the steric requirement of the reducing agents used.²¹ Recently, we reported the formation of halomagnesium dialkylaminoborohydrides as a byproduct of the reaction of Grignard reagents with diisopropylaminoborane.²² Our studies have shown that the reducing characteristics of dialkylaminoborohydrides are very sensitive to the cationic counterions. Herein, we present a full account summarizing our results of the controlled reductions of aliphatic and aromatic amides to the corresponding alcohols, aldehydes, and amines with dialkylboranes and metal dialkylaminoborohydrides.

2. RESULTS AND DISCUSSION

Reduction of Amides Using Dialkylboranes. Dialkylboranes have been shown to be excellent hydroborating reagents as well as reducing agents.²³ For our initial amide reduction study, we chose simple dialkylboranes starting with the commercially available and air-stable 9-borabicyclo[3.3.1]nonane (9-BBN). To explore the effects of the steric requirements of the dialkylboranes in stabilizing the tetrahedral intermediates formed in the reduction of amides, we chose dicyclohexylborane (Chx_2BH), and the more hindered disiamylborane (Sia_2BH). These dialkylboranes were readily synthesized from the corresponding alkenes and borane dimethylsulfide (BMS). Reduction of tertiary amides using dicyclohexylborane (Chx_2BH) generally gave minimal amounts of the corresponding aldehydes along with unreacted starting materials; no alcohol or amine products were detected.²⁴ However, when 1 equiv of disiamylborane (Sia_2BH) was allowed to react with *N,N*-dimethylbenzamide over a period of 12 h, benzaldehyde was the only product observed by GC analysis (eq 1).

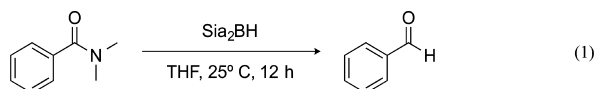

The generality of the reaction with Sia_2BH was demonstrated by the reduction of other tertiary amides to the corresponding aldehydes (Table 1).

This study demonstrated that the Sia_2BH reductions are general, clean, and produced only the corresponding aldehydes.

When *N,N*-diethylbenzamide was allowed to react with 1 equiv of 9-BBN at room temperature, a mixture of the expected amine and unreacted amide was isolated. However, when *N,N*-diethylbenzamide was allowed to react with 2 equiv of 9-BBN, the corresponding amine was produced in 80% yield (eq 2).

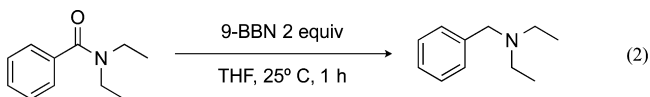

The progress of the reactions was monitored by ¹¹B NMR spectroscopy by following the disappearance of the signal at δ +27 due to the 9-BBN dimmer and appearance of the signal at δ +56 due to oxybis-9-BBN (BOB compound of 9-BBN). It was speculated that the reaction of tertiary amides with 9-BBN is analogous to reactions with LiAlH_4 and $\text{BH}_3\cdot\text{THF}$. The first equivalent of 9-BBN reduces the amide carbonyl to give the corresponding tetrahedral intermediate, B-O-hemiaminal. It is plausible that nitrogen lone pair assisted elimination would lead to formation of an iminium ion, which, in turn, is reduced by

Table 1. Reduction of Tertiary Amides with Disiamylborane^a

Entry	Amide	Product	% Yield ^b
1			89
2			68
3			70
4			77
5			85
6			99

^aReactions conducted on a 5 mmol scale with 1 equiv of amide and 1 equiv of Sia_2BH , followed by oxidative workup. Results taken from ref 25. ^bGC yield.

the second equivalent of 9-BBN to yield the tertiary amine and BOB compound of 9-BBN. The reduction of amides with 9-BBN was rapid, clean, and essentially quantitative (Table 2).

Most reductions were complete within 1 h, but the reduction of an amide derived from a cyclic amine was slower, requiring 12 h for completion (Table 2, entry 4). Of interest is the reaction of *N*-methoxy-*N*-methylbenzamide, which was reduced to *N*-methoxy-*N*-methylbenzylamine (Table 2, entry 5).

The steric requirement of dialkylboranes was found to play a major role in the reductions of tertiary amides. The sterically demanding Sia_2BH reacted with amides to yield aldehydes, while reaction with 9-BBN afforded the corresponding amines. The reductions are independent of the steric bulk of the amides. Thus, tertiary amides can be reduced to either the corresponding amines or the corresponding aldehydes, depending on the choice of dialkylborane. After studying the reduction of amides with 9-BBN and Sia_2BH , we turned our attention toward the reduction of amides with aminoborohydride reagents.

Reduction of Amides Using Lithium Aminoborohydrides. Early work with sodium aminoborohydrides established the reduction of amides to alcohols.²⁵ Unfortunately, mixtures of products were often obtained and the steric environment of both the amide and the sodium aminoborohydride required careful balancing to achieve the desired products. The sterically unhindered lithium pyrrolidino-borohydride (PyrrLAB) proved a more reliable alternative, reducing amides to the corresponding alcohols with no

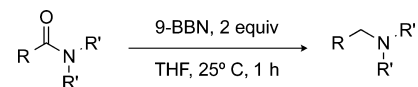
Table 2. Reduction of Tertiary Amides with 9-BBN^a

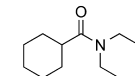
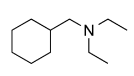
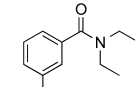
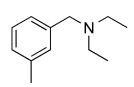
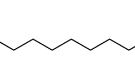
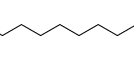
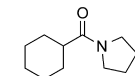
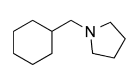
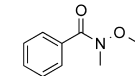
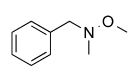
Entry	Amide	Product	% Yield ^b
1			76
2			83
3			88
4			82 ^c
5			86

^aReactions conducted on a 5 mmol scale with 1 equiv of amide and 2 equiv of 9-BBN, followed by aqueous acidic workup. ^bIsolated yield. ^c12 h.

byproducts.²⁶ Studies on the reactivity of LAB reagents indicated that the reduction of tertiary amides to alcohols is a general method for unhindered LAB reagents and represents a substantial improvement over other reducing agents. One equivalent of reagent was sufficient to reduce amides to alcohols within 3 h (Table 3).

The reductions were general, reducing the unhindered *N,N*-dimethylbenzamide and *N,N*,3-trimethylbenzamide (Table 3, entries 1 and 2), as well as the hindered *N,N*-diisopropylbenzamide (Table 3, entry 3).

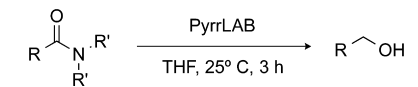
Table 3. Reduction of Amides with Lithium Pyrrolidinoborohydride^a

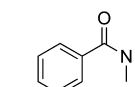
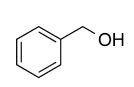
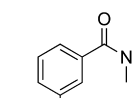
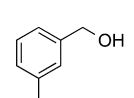
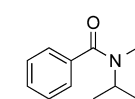
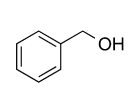
Entry	Amide	Product	% Yield ^b
1			71 ^c
2			95 ^c
3			99 ^c

^aReactions conducted on a 2 mmol scale with 1 equiv of amide and 1 equiv of LAB, followed by aqueous acidic workup. ^bIsolated yield. ^cTaken from ref 26.

Interestingly, reduction of unhindered tertiary amides, such as *N,N*-dimethylbenzamide, provides benzyl alcohol regardless of the LAB reagent used. When reducing more sterically demanding tertiary amides, selective C–O or C–N bond cleavage can be achieved through variation of the steric environment on the amine moiety of the LAB reagent.²⁷ For example, reduction of 1-pyrrolidinooctanamide with PyrLAB provides 1-octanol in 77% yield, while the same reaction with the more sterically crowded lithium diisopropylamino-borohydride (*i*PrLAB) provides *N*-octylpyrrolidine in 95% yield (Scheme 1).

Scheme 1. Chemoselective Reduction of Tertiary Amides with LAB Reagents

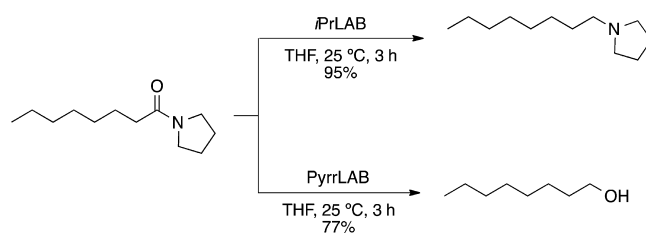

The selectivity of this reduction appears to involve a common intermediate, **1**, the initial reduction product of the amide (Figure 1).^{21c}

From intermediate **1**, there are two possible routes to the corresponding amine or alcohol. In Path A, the iminium species **3** is formed by the expulsion of the lithium dihydroamino-borinate **2** by the nitrogen lone pair. This iminium is then reduced to the corresponding amine **4** by remaining LAB reagent. In Path B, the complexation of an aminoborane to the nitrogen of **1** converts the amine to the ammonium moiety **5**, making it a better leaving group. Cleavage of the B–O bond and subsequent expulsion of the diamino-dihydroborohydride moiety produces aldehyde **6**, which can be rapidly reduced to the corresponding alcohol **7**. During this study, the sterics of the amide as well as the LAB reagent were found to dictate the route of the reaction. As the amino groups in the LAB reagent become more sterically demanding, the formation of the amine product through C–O bond cleavage is favored. It has been thought that unfavorable steric interactions between the LAB reagent and the amide nitrogen are responsible for this trend. In contrast, reductions performed using LiAlH₄ predominantly form the amine product through C–O bond cleavage, while those carried out using LiEt₃BH produce the alcohol product through C–N bond cleavage.²⁸

Reduction of Lactams to Amines Using Lithium Aminoborohydrides. The reduction of lactams to amines is an important transformation in the synthesis of biologically active pharmaceutical compounds. This reduction has been reported with many reagents including DIBAL,²⁹ NaBH₄,³⁰ and borane-tetrahydrofuran (H₃B:THF).³¹ Previously, we reported the reduction of various *N*-alkyl lactams to the cyclic amines using lithium dimethylaminoborohydride, MeLAB (Table 4).³²

The reduction of lactams with MeLAB proved facile, giving the cyclic amine product in very good to excellent yields. This was of particular interest, as the unhindered LAB reagent gave C–O bond cleavage.

Reductions of Amides Using Chloromagnesium Aminoborohydrides. Borohydride reagents show a trend of increased reactivity with smaller cations. For instance, the

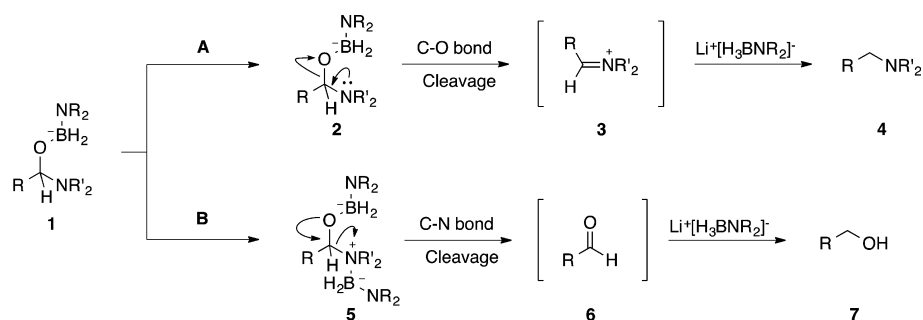

Figure 1. Mechanism of the reduction of tertiary amides with lithium aminoborohydrides.

Table 4. Reduction of Lactams to Amines with Lithium Dimethylaminoborohydride^a

Entry	Lactam	Amine	% Yield ^b
1			89
2			86
3			96

^aReactions conducted on a 5 mmol scale with 1 equiv of lactam and 1.5 equiv of aminoborohydride, THF, 65 °C. ^bIsolated yield.

reactivity of lithium, sodium, and potassium borohydrides decreases in the series $\text{LiBH}_4 > \text{NaBH}_4 > \text{KBH}_4$.³³ Sodium aminoborohydrides have been shown to reduce amides, though the reductions were not facile and required long reaction times and drastic conditions.²⁶ In contrast, reductions with lithium aminoborohydrides proved to be facile and general. We recently synthesized chloromagnesium dimethylaminoborohydride (MgAB) by reacting dimethylamine-borane with an equivalent of methylmagnesium chloride (Scheme 2).²²

Scheme 2. Synthesis of MgAB from Dimethylamine-borane

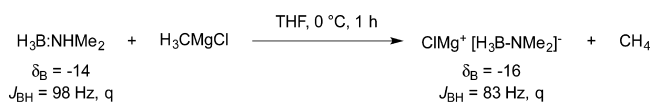

In the ¹¹B NMR spectrum, the MgAB species appears as a quartet at δ_B -16 ppm, while the starting amine-borane has a chemical shift of δ_B -14 ppm. The starting material and the product are further distinguished by their coupling constants; dimethylamine-borane exhibits a quartet with $J_{\text{BH}} = 98$ Hz, while the product chloromagnesium dimethylaminoborohydride has $J_{\text{BH}} = 83$ Hz. When synthesizing MgAB, chloride-based Grignard reagent, MeMgCl , gives complete conversion. Solutions of MgAB can be stored under an inert atmosphere at room temperature for at least 3 months without any disproportionation, as monitored by ¹¹B NMR. We used this stock solution to investigate the reductions of amides.

To begin the study, benzamide was allowed to react with MgAB at room temperature. The reaction was exothermic, followed by the immediate formation of a white precipitate. Analysis by ¹¹B NMR showed the appearance of the dimethylamine-borane (δ_B -14, q, $J_{\text{BH}} = 98$ Hz). Evidently, the amide proton is acidic enough to quench MgAB to form the amine-borane, forming a precipitate. Aminoborohydride reagents have proven sensitive to acidic compounds with pK_a values < 16, reverting back to amine-boranes.^{23c} Similar results were observed upon reaction of MgAB with *N*-methylbenzamide. These observations indicated that primary and secondary amides are not amenable to reduction with MgAB. Thus, attention was turned to reductions of tertiary amides using MgAB.

When 1 equiv of MgAB was allowed to react with *N,N*-dimethylbenzamide, benzyl alcohol was isolated following aqueous quench (eq 3).

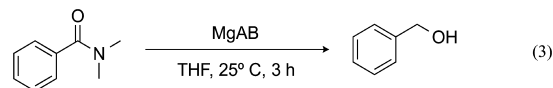

Previous reports demonstrated the ability of LAB reagents to reduce esters at reduced temperatures,^{21c} and nitriles under refluxing conditions.^{21f} Similar reactivity was investigated with MgAB. When methyl benzoate was allowed to react with 1 equiv of MgAB, no reduction was observed after 12 h at room temperature. In a similar experiment, no reaction was observed when benzonitrile was allowed to react with MgAB under reflux. This observation prompted further investigation of the reaction of MgAB with amides. When 4-cyano-*N*-methoxy-*N*-methylbenzamide was allowed to react with MgAB, the corresponding alcohol was isolated in 74% following aqueous quench (eq 4).

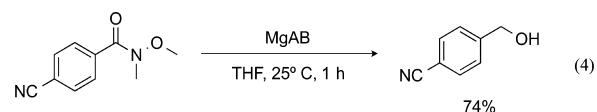

Similar results were obtained from the reaction of methyl 4-(methoxy(methyl)carbamoyl)benzoate with MgAB: isolation of the corresponding alcohol in 92% yield (eq 5).

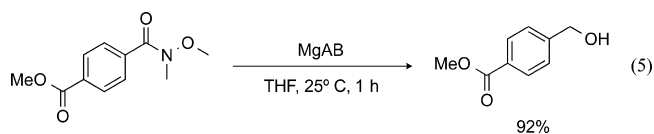

These results indicated a unique chemoselectivity profile for MgAB; reducing amides in the presence of nitrile and ester groups.

Table 5. Reduction of Weinreb Amides to Aldehydes with MgAB^a

1. MgAB
THF, 25 °C, 30 min
2. MeCHO/AcOH
3. Aq. NaHSO₃
4. Aq. H₂C=O

Entry	Amide	Product	% Yield ^b	Entry	Amide	Product	% Yield ^b
1			75	8			70
2			74	9			75
3			81	10			80
4			82	11			70
5			70	12			89
6			81	13			74
7			74				

^aReactions conducted on a 2 mmol scale with 1 equiv of Weinreb amide and 1 equiv of MgAB. ^bIsolated yield of aldehyde after liberation from bisulfite adduct.

Reduction of Amides to Aldehydes Using Magnesium Aminoborohydrides. Recently, we reported the partial reduction of amides to aldehydes using MgAB.³⁴ The partial reduction of *N*-methoxy-*N*-methylbenzamide to benzaldehyde using MgAB was investigated as a model substrate. One equivalent of MgAB reduced *N*-methoxy-*N*-methylbenzamide to benzaldehyde in 30 min at 25 °C, as evidenced by TLC analysis. Acidic quench and aqueous workup lead to over-reduction to the alcohol. We then tried various modifications to our workup procedure to minimize the reduction of our aldehyde products to the corresponding alcohol. Dropwise transfer of the reaction mixture to a pentane solution (reverse quench) containing acetaldehyde and acetic acid prevented over-reduction, but contamination with aldol byproducts was observed. Attempted purification of the crude aldehydes by silica gel column chromatography resulted in the isolation of almost pure alcohol. Dimethylaminoborane (Me₂N-BH₂), the byproduct from MgAB, exists as a stable dimer and is usually unreactive to aldehydes.³⁵ Evidently, activation of the aldehyde carbonyl by silica gel results in the reduction of the aldehyde, similar to that observed for the silica gel-promoted reduction by *N*-heterocyclic carbene boranes.³⁶ We then tried the well-established procedure of isolating the pure aldehydes by

addition of bisulfite.³⁷ Separating insoluble bisulfite adducts from the crude reaction mixture, followed by the regeneration of the aldehyde, allowed for the isolation of aldehydes in essentially pure form (Table 5).³⁸

Weinreb amides of varying steric and electronic nature were reduced under these mild conditions. Aromatic substrates bearing electron-donating (Table 5, entries 2–4) or electron-withdrawing (Table 5, entries 6–9) groups were amenable to reduction without complication. Reduction was even observed for substrates with increased steric demand (Table 5, entries 2 and 7). Furthermore, the cinnamic amide was reduced without over-reduction to cinnamyl alcohol as a side product (Table 5, entry 5).^{18a,b} The reduction of the cinnamic amide demonstrated that 1,2-reduction in the absence of 1,4-reduction is possible using MgAB. Aliphatic Weinreb amides were also amenable to reduction with this methodology (Table 5, entry 10). Of particular interest is the chemoselective reduction of the substituted amides by MgAB. (Table 5, entry 5). The chemoselectivity was further explored by examining the reduction of the amide moiety in the presence of ester (Table 3, entry 11), nitro (Table 5, entry 12), and nitrile (Table 3, entry 13) functionalities. These results indicate a unique chemoselectivity profile for MgAB.

Table 6. Reduction of Tertiary Amides to Aldehydes with MgAB^a

Entry	Amide	Product	% Yield ^b	Entry	Amide	Product	% Yield ^b
1			74 ^c	7			53 ^e
2			65 ^c	8			65 ^e
3			63 ^d	9			60 ^e
4			70 ^d	10			74 ^f
5			92 ^d	11			70 ^f
6			74 ^d				

^aReactions conducted on a 2 mmol scale with 1 equiv of amide and 1 equiv of MgAB. ^bIsolated yield of aldehyde after column chromatography. ^c30 min. ^d3 h. ^e4 h. ^f5 h.

Since morpholine-derived amides were also relatively reactive with MgAB, various examples were selected for the study.¹⁴ Thus, the acyl morpholine of benzoic acid was allowed to react with MgAB at 25 °C, and the reaction progress was monitored by TLC. The acyl morpholine was consumed, affording benzaldehyde within 3 h. As with Weinreb amides, reverse quench of the reaction mixture by addition to a pentane solution of acetaldehyde and acetic acid prevented the over-reduction to benzyl alcohol. Similar results were observed upon reaction of MgAB with the acyl pyrrolidine of benzoic acid, which afforded benzaldehyde after 4 h. Lastly, reaction of *N,N*-dimethylbenzamide with MgAB, followed by reverse quench, afforded benzaldehyde after 5 h of reaction at 25 °C. Attempts to reduce amides with more sterically demanding substitution on the amide nitrogen with MgAB resulted in no reaction. *N,N*-Diethylbenzamide and *N,N*-diisopropylbenzamide were unreactive with MgAB even after extended reaction times at 25 °C and were isolated quantitatively at the end of the reaction.

Having demonstrated the ability of MgAB to reduce several tertiary amides to aldehydes, attention was turned to optimizing an efficient isolation procedure. Short-path column chromatography can be utilized with the use of aluminum oxide (basic alumina) instead of silica gel. Basic alumina is a common solid phase for various chromatographic procedures. Contrary to observations with silica gel, basic alumina did not activate the aldehyde carbonyl, preventing further reduction. Reaction of *N*-methoxy-*N*-methylbenzamide with MgAB, followed by reverse quench and alumina column chromatography, affords benzaldehyde in 74% yield. Isolation of aldehydes by basic alumina chromatography was found to be simpler, faster, and more

practical than the formation, isolation, and liberation of bisulfite adducts (Table 6).

Aromatic and aliphatic amides are reduced to the aldehydes in good yields. Substitution of the aromatic substrates with electron-donating (Table 6, entries 6 and 8) or electron-withdrawing groups (Table 6, entries 5, 7, and 11) does not significantly alter the reaction course. Aliphatic amides are viable substrates (Table 6, entries 2 and 4), highlighting the generality of this reduction. One equivalent of MgAB is required for aldehyde formation from aliphatic and aromatic amides. The rate of reduction of Weinreb amides indicated that the magnesium counterion plays a crucial role in chelating with the *N*-methoxy group. This trend accounts for the observed reaction time of dimethyl amides (5 h) versus morpholine amides (3 h), as well as Weinreb amides (30 min).

The controlled reduction of amides to aldehydes with MgAB expands the versatility of amide reduction by aminoborohydrides. LAB reagents have been used to reduce amides to give either the corresponding alcohols or amines.^{21c} Reduction of amides with the sterically unhindered PyrLAB yields alcohols, whereas reaction with the sterically more demanding lithium diisopropylaminoborohydride *i*PrLAB yields amines. The reduction of amides to aldehydes with MgAB prompted a reevaluation of the reactivity of MeLAB. It was reasoned that the reduction of an amide with MeLAB to the corresponding alcohols must have been proceeding through an aldehyde intermediate. Our earlier studies with MeLAB never explored the possibility of reduction to the corresponding aldehydes. With the insight gained from our MgAB studies, the reduction of amides to aldehydes with MeLAB was explored. Using the optimized procedure from MgAB reductions, *N*-methoxy-*N*-

methylbenzamide was allowed to react with an equivalent of MeLAB. As monitored by TLC, the amide was consumed in 30 min, and the aldehyde was isolated in 77% yield (eq 6).

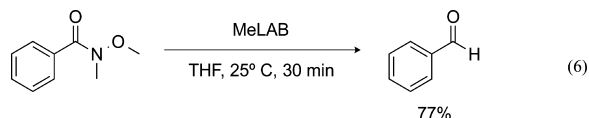

Similarly, the morpholine amide of benzoic acid was allowed to react with an equivalent of MeLAB. Benzaldehyde was isolated in 74% yield after 2 h (eq 7).

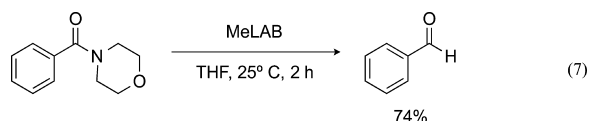

Observed reaction times were comparable to those of MgAB. The reduction of the Weinreb amides was complete within 30 min, while the morpholine amide was consumed within 2 h. These reductions of amides to aldehydes suggest a broader applicability of LAB reagents in the reduction of amides.

3. CONCLUSION

Dialkylboranes and aminoborohydride reagents are versatile, yet selective reducing agents (Figure 2).

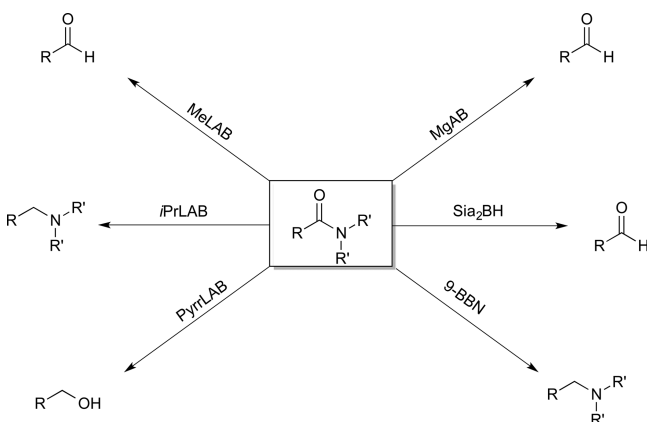

Figure 2. Reduction of tertiary amides with dialkylboranes and aminoborohydride reagents.

Disiamylborane reduces amides to aldehydes at room temperature. Two equivalents of 9-BBN reduces amides to the corresponding amines. 9-BBN is commercially available and air-stable, while Sia_2BH is easily prepared from the precursor alkene. Ease of generation and handling and the simple workup procedures for performing reductions with aminoborohydrides make these reagents attractive for the selective reductions of tertiary amides. LAB reagents are prepared from butyllithium and the corresponding amine-borane. Reduction of amides with unhindered PyrrLAB affords the corresponding alcohols, while reduction with the hindered *i*PrLAB affords the corresponding amines. Chloromagnesium dimethylaminoborohydride (MgAB) was prepared by the reaction of methylmagnesium chloride with dimethylamine-borane and was used for the controlled reduction of amides to the corresponding aldehydes. MgAB was shown to reduce a series of tertiary amides to aldehydes, but was unreactive to sterically demanding amides. Reverse quench of the reaction mixture utilizing a sacrificial electrophile, such as acetaldehyde, afforded the crude aldehyde.

The aldehyde products were effectively isolated as the corresponding bisulfite adducts, or using column chromatography of the crude reaction material on basic alumina. MgAB exhibits a unique chemoselective profile, capable of reducing amides in the presence of a nitro group, a nitrile, an ester, and a conjugated double bond. The results of the amide reduction study with MgAB prompted an investigation into the reaction of lithium dimethylaminoborohydride with amides, which was also shown to effect the reduction of amides to aldehydes. This work demonstrates the broad reactivity of dialkylboranes and metal dimethylaminoborohydride reagents.

4. EXPERIMENTAL SECTION

General Methods. All reactions were performed in oven-dried, argon-cooled glassware. The dimethylamine-borane was dried as received from a chemical supplier. The pinacolborane was used as received from a chemical supplier and stored under argon in a refrigerator held at 5 °C. All Grignard reagents were used as received and were stored at room temperature. All air- and moisture-sensitive compounds were introduced via syringe or cannula through a rubber septum. Pinacolborane was added via syringe, with the dispensed amounts measured by mass difference of the syringe before and after addition. The concentrations of the Grignard reagents were monitored using the titration method described by Knochel.³⁹ Tetrahydrofuran (THF) was freshly obtained from a solvent purification system (Pure Solv MD, Innovative Technology Inc.). NMR spectra were recorded at 500 MHz (¹H), 125 MHz (¹³C), and 160.4 MHz (¹¹B). All ¹H NMR and ¹³C NMR chemical shifts are reported in δ units relative to the respective solvent of the NMR sample. ¹¹B NMR samples are reported relative to the external standard $\text{BF}_3 \cdot \text{Et}_2\text{O}$ ($\delta_{\text{B}} = 0$). Data are reported as follows: chemical shift, multiplicity (s = singlet, d = doublet, t = triplet, q = quartet, m = multiplet), coupling constant, and integration.

General Procedure for the Preparation of Lithium Dimethylaminoborohydride, 1 M Solution in THF. To an oven-dried, argon-cooled 100 mL round-bottom flask equipped with a stir bar and septum was added dimethylamine-borane (2.95 g, 50 mmol), followed by anhydrous THF (27 mL), and the mixture was cooled to 0 °C (ice bath). To the solution was added *n*-butyllithium (20 mL, 2.5 M, 50 mmol) dropwise via cannula needle (**Caution! Gas evolution**). After stirring at 0 °C for 1 h, an aliquot was taken and analyzed by ¹¹B NMR, which showed the solution to be lithium dimethylaminoborohydride ($\delta_{\text{B}} -16$, q, $J_{\text{BH}} = 83$ Hz). The LAB reagent was transferred to an oven-dried, argon-cooled ampule via a cannula needle. Note that, although the chemical shift of the corresponding amine-borane complex is close to that of the MeLAB, the J_{BH} values of dimethylamine-borane are 98 Hz.

General Procedure for the Preparation of Chloromagnesium Dimethylaminoborohydride, 1 M Solution in THF. An oven-dried, argon-cooled 50 mL round-bottom flask equipped with a stir bar and septum was charged with an ethereal solution of MeMgCl (10.35 mL, 2.9M, 30 mmol) and cooled to 0 °C (ice bath). A 1.5 M solution of dimethylamine-borane in THF (20 mL, 30 mmol) was added with stirring over a period of 40 min. After 1 h of stirring, a 0.4 mL aliquot was taken for ¹¹B NMR analysis. The ¹¹B NMR spectrum indicated formation of the chloromagnesium aminoborohydride product ($\delta_{\text{B}} -16$, q, $J_{\text{BH}} = 83$ Hz). The MgAB solution was then transferred to an oven-dried, argon-cooled ampule via a cannula for storage. Note that, although the chemical shift of the corresponding amine-borane complex is close to that of the MgAB, the J_{BH} values of dimethylamine-borane are 98 Hz.

General Procedure for the Reduction of Lactams to Amines with MeLAB. The following procedure for the reduction of 4-methyl-2H-benzo[*b*][1,4]oxazin-3(4H)-one is representative. To an oven-dried and argon-cooled 50 mL round-bottom flask equipped with a side arm, stir bar, and condenser was added chloromagnesium dimethylaminoborohydride (MeLAB, 7.5 mL, 1M, 7.5 mmol). To the solution, 4-methyl-2H-benzo[*b*][1,4]oxazin-3(4H)-one (0.816 g, 5 mmol) was added neat via syringe. The reaction mixture was heated to reflux. After 2 h, the reaction was cooled to 0 °C (ice bath) and

quenched by the slow addition of 3 M HCl (12 mL) (*Caution! Hydrogen evolution*). The aqueous layer was then extracted with Et₂O (4 × 20 mL) and cooled to 0 °C (ice bath). To the aqueous layer was added solid NaOH until basic to litmus, and the aqueous layer was extracted with Et₂O (4 × 20 mL). The organic fractions were combined, dried over MgSO₄, and concentrated under reduced pressure to give 4-methyl-3,4-dihydro-2H-benzo[b][1,4]oxazine as a brown oil (0.599 g, 80% yield). For other amines prepared by this method, see Table 4.

N-Octylpyrrolidine.^{21c} Clear oil (0.664 g, 72% yield). ¹H NMR (500 MHz, CDCl₃): δ 2.49–2.44 (m, 4H), 2.38 (d, *J* = 8.1 Hz, 2H), 1.80–1.70 (m, *J* = 3.8 Hz, 4H), 1.54–1.44 (m, 2H), 1.25 (s, 10H), 0.86 (t, *J* = 6.7 Hz, 3H) ppm. ¹³C NMR (125 MHz, CDCl₃): δ 56.6, 54.1, 31.7, 29.5, 29.1, 28.9, 27.6, 23.2, 22.5, 13.9.

N-Benzylpyrrolidine.⁴⁰ Yellow oil (0.577 g, 72% yield). ¹H NMR (500 MHz, CDCl₃): δ 7.34–7.19 (m, 5H), 3.59 (s, 2H), 2.53–2.44 (m, 4H), 1.76 (m, 4H) ppm. ¹³C NMR (125 MHz, CDCl₃): δ 139.4, 128.9, 128.2, 126.9, 60.8, 54.2, 23.4.

4-Methyl-3,4-dihydro-2H-benzo[b][1,4]oxazine.⁴¹ Brown oil (0.599 g, 80% yield). ¹H NMR (500 MHz, CDCl₃): δ 6.85–6.78 (m, 1H), 6.79–6.73 (m, 1H), 6.66–6.61 (m, 2H), 4.25–4.19 (m, 2H), 3.18–3.12 (m, 2H), 2.80 (s, 3H) ppm. ¹³C NMR (125 MHz, CDCl₃): δ 144.3, 136.6, 121.4, 118.2, 115.9, 112.6, 49.1, 38.7.

General Procedure for the Reduction of Amides to Alcohols with MgAB. The following procedure for the reduction of *N,N*-dimethylbenzamide is representative. To an oven-dried and argon-cooled 50 mL round-bottom flask equipped with a magnetic stirring bar and fitted with a rubber septum was added *N,N*-dimethylbenzamide (0.350 g, 2 mmol), followed by anhydrous THF (1.6 mL). To the stirred solution was added MgAB (2.5 mL, 1M, 2.5 mmol). After 3 h of stirring, the reaction mixture was cooled to 0 °C and quenched by the slow addition of 3 M HCl (4 mL, 12 mmol) (*Caution! Hydrogen evolution*). The aqueous and organic fractions were separated, and the aqueous fraction was extracted with Et₂O (3 × 10 mL). The combined ethereal fractions were washed with 3 M NaOH (3 × 10 mL), dried over MgSO₄, and concentrated under reduced pressure to yield benzyl alcohol as a clear oil (0.180 g, 83%).

Benzyl Alcohol.⁴² Clear oil (0.180 g, 83% yield). ¹H NMR (500 MHz, CDCl₃): δ 7.26–7.13 (m, 5H), 4.43 (s, 2H), 3.43 (s, 1H) ppm. ¹³C NMR (125 MHz, CDCl₃): δ 140.9, 128.5, 127.5, 127.0, 64.9.

4-(Hydroxymethyl)benzointrile.⁴² Clear oil (0.197 g, 74% yield). ¹H NMR (500 MHz, CDCl₃): δ 7.57 (d, *J* = 8.1 Hz, 2H), 7.42 (d, *J* = 8.1 Hz, 2H), 4.70 (s, 2H), 3.09 (s, 1H) ppm. ¹³C NMR (125 MHz, CDCl₃): δ 146.6, 132.2, 127.0, 118.9, 110.7, 63.9.

Methyl 4-(Hydroxymethyl)benzoate.⁴² Clear oil (0.306 g, 92% yield). ¹H NMR (500 MHz, CDCl₃): δ 7.93 (d, *J* = 8.3 Hz, 2H), 7.34 (d, *J* = 8.3 Hz, 2H), 4.68 (s, 2H), 3.84 (s, 3H) ppm. ¹³C NMR (125 MHz, CDCl₃): δ 167.2, 146.2, 129.9, 129.3, 126.6, 64.7, 52.2.

General Procedure for the Reduction of Weinreb Amides to Aldehydes with MgAB Purified by Bisulfite Adduct Formation.

The following procedure for the reduction of *N*-methoxy-*N*-methylbenzamide by MgAB is representative. To an oven-dried and argon-cooled 25 mL round-bottom flask equipped with a stir bar and septum was added *N*-methoxy-*N*-methylbenzamide (0.305 mL, 2 mmol), followed by THF (1.7 mL). Chloromagnesium dimethylaminoborohydride (MgAB, 2 mL, 1M, 2 mmol) was then added dropwise via a syringe. The reaction was monitored by TLC (Hex/EtOAc, 1:1). After 30 min, the reaction solution was added dropwise to a solution of acetaldehyde (2 mmol) and acetic acid (2 mmol) in pentane (10 mL). After 15 min, saturated aqueous NH₄Cl (2 mL) was added. The organic layer was separated, and the aqueous phase was extracted with Et₂O (2 × 10 mL). The combined organic layers were washed with 1 M HCl (10 mL), dried with magnesium sulfate, and concentrated under reduced pressure to yield crude aldehyde as an orange oil. The crude aldehyde (2 mmol) was transferred to a round-bottom flask equipped with a magnetic stir bar, followed by EtOH (3 mL) and EtOAc, (5 mL) and cooled with an ice bath. A saturated aqueous solution of NaHSO₃ (1 mL) was added with stirring. After 4 h, the solid bisulfite adduct was isolated by vacuum filtration, washed with Et₂O (3 × 5 mL), and dried under vacuum to yield a white solid. The

bisulfite adduct was then added to a round-bottom flask dissolved in H₂O (10 mL), and a 37% formalin solution (2 mL) was added, followed by Et₂O (20 mL). The biphasic solution was stirred for 1 h. The aqueous layer was separated and extracted with a 1:1 mixture of THF/Et₂O (3 × 10 mL). The combined organic layers were dried over magnesium sulfate and concentrated under reduced pressure to give the aldehyde as a pale yellow oil (0.160 g, 75% yield). For other aldehydes prepared by this method, see Table 5.

Benzaldehyde.⁴³ Pale yellow oil (0.160 g, 75% yield). ¹H NMR (500 MHz, CDCl₃): δ 9.99 (s, 1H), 7.86–7.84 (m, 2H), 7.61–7.58 (m, 1H), 7.51–7.47 (m, 2H) ppm. ¹³C NMR (125 MHz, CDCl₃): δ 192.5, 136.5, 134.5, 129.8, 129.1 ppm.

o-Tolualdehyde.⁴⁴ Pale yellow oil (0.178 g, 74% yield). ¹H NMR (500 MHz, CDCl₃): δ 10.25 (s, 1H), 7.80–7.76 (m, 1H), 7.49–7.44 (m, 1H), 7.37–7.32 (m, 1H), 7.26–7.23 (m, 1H), 2.66 (s, 3H) ppm. ¹³C NMR (125 MHz, CDCl₃): δ 193.0, 140.7, 134.3, 133.8, 132.2, 131.9, 126.5, 19.7 ppm.

3,5-Dimethylbenzaldehyde.⁴³ Pale yellow oil (0.217 g, 81% yield). ¹H NMR (500 MHz, CDCl₃): δ 9.95 (s, 1H), 7.49 (s, 2H), 7.27 (s, 1H), 2.39 (s, 6H) ppm. ¹³C NMR (125 MHz, CDCl₃): δ 192.9, 138.8, 136.7, 136.3, 127.6, 21.2 ppm.

p-Methoxybenzaldehyde.⁴³ Yellow oil (0.223 g, 82% yield). ¹H NMR (500 MHz, CDCl₃): δ 9.83 (s, 1H), 7.79 (d, *J* = 8.8 Hz, 2H), 6.96 (d, *J* = 8.8 Hz, 2H), 3.83 (s, 3H) ppm. ¹³C NMR (125 MHz, CDCl₃): δ 190.8, 164.6, 132.0, 129.9, 114.3, 55.6 ppm.

trans-Cinnamaldehyde.⁴³ Yellow oil (0.185 g, 70% yield). ¹H NMR (500 MHz, CDCl₃): δ 9.67 (d, *J* = 7.7 Hz, 1H), 7.55–7.38 (m, 6H), 6.69 (dd, *J* = 15.9, 7.7 Hz, 1H) ppm. ¹³C NMR (125 MHz, CDCl₃): δ 193.8, 152.9, 134.0, 131.3, 129.1, 128.5, 128.5 ppm.

3-Bromo-4-methylbenzaldehyde.⁴⁵ White solid (0.322 g, 81% yield). ¹H NMR (500 MHz, CDCl₃): δ 9.91 (s, 1H), 8.02 (d, *J* = 1.9 Hz, 1H), 7.71 (dd, *J* = 7.7, 1.9 Hz, 1H), 7.40 (d, *J* = 7.7 Hz, 1H), 2.48 (s, 3H) ppm. ¹³C NMR (125 MHz, CDCl₃): δ 190.4, 145.1, 135.8, 133.3, 131.3, 128.4, 125.60, 23.4 ppm.

o-Bromobenzaldehyde.⁴⁶ Pale yellow oil (0.274 g, 74% yield). ¹H NMR (500 MHz, CDCl₃): δ 10.36 (s, 1H), 7.93–7.89 (m, 1H), 7.66–7.63 (m, 1H), 7.46–7.41 (m, 2H) ppm. ¹³C NMR (125 MHz, CDCl₃): δ 192.1, 135.5, 134.1, 133.7, 130.1, 128.1, 127.3 ppm.

p-Chlorobenzaldehyde.⁴³ White solid (0.197 g, 70% yield). ¹H NMR (500 MHz, CDCl₃): δ 9.98 (s, 1H), 7.82 (d, *J* = 8.4 Hz, 2H), 7.51 (d, *J* = 8.4 Hz, 2H) ppm. ¹³C NMR (125 MHz, CDCl₃): δ 191.0, 141.1, 134.8, 131.0, 129.6 ppm.

p-Trifluoromethylbenzaldehyde.⁴³ Pale yellow oil (0.261 g, 75% yield). ¹H NMR (500 MHz, CDCl₃): δ 10.10 (s, 1H), 8.01 (d, *J* = 7.6 Hz, 2H), 7.81 (d, *J* = 7.6 Hz, 2H) ppm. ¹³C NMR (125 MHz, CDCl₃): δ 191.3, 138.9, 135.8 (d, *J* = 32.9 Hz), 130.1, 126.3 (q, *J* = 3.8 Hz), 125.0 ppm.

Octanal.⁴⁴ Pale yellow oil (0.205 g, 80% yield). ¹H NMR (500 MHz, CDCl₃): δ 9.72 (s, 1H), 2.41–2.34 (m, 2H), 1.63–1.51 (m, 2H), 1.32–1.17 (m, 8H), 0.87–0.79 (m, 3H) ppm. ¹³C NMR (125 MHz, CDCl₃): δ 202.9, 44.0, 31.7, 29.2, 29.1, 22.6, 22.2, 14.1 ppm.

Methyl 4-Formylbenzoate.⁴⁴ White solid (0.230 g, 70% yield). ¹H NMR (500 MHz, CDCl₃): δ 10.10 (s, 1H), 8.19 (d, *J* = 8.4 Hz, 2H), 7.95 (d, *J* = 8.4 Hz, 2H), 3.96 (s, 3H) ppm. ¹³C NMR (125 MHz, CDCl₃): δ 191.8, 166.2, 139.3, 135.3, 130.4, 129.7, 52.8 ppm.

p-Nitrobenzaldehyde.⁴³ Yellow solid (0.269 g, 89% yield). ¹H NMR (500 MHz, CDCl₃): δ 10.16 (s, 1H), 8.39 (d, *J* = 8.6 Hz, 2H), 8.07 (d, *J* = 8.6 Hz, 2H) ppm. ¹³C NMR (125 MHz, CDCl₃): δ 190.4, 151.2, 140.2, 130.6, 124.4 ppm.

p-Cyanobenzaldehyde.⁴⁷ White solid (0.194 g, 74% yield). ¹H NMR (500 MHz, CDCl₃): δ 10.10 (s, 1H), 8.00 (d, *J* = 8.3 Hz, 2H), 7.85 (d, *J* = 8.3 Hz, 2H) ppm. ¹³C NMR (125 MHz, CDCl₃): δ 190.9, 138.9, 133.1, 130.1, 117.9, 117.8 ppm.

General Procedure for the Reduction of Amides to Aldehydes with MgAB, Purified by Alumina Column Chromatography.

The following procedure for the reduction of *N*-methoxy-*N*-methylbenzamide by MgAB is representative. To an oven-dried and argon-cooled 25 mL round-bottom flask equipped with a stir bar and septum was added *N*-methoxy-*N*-methylbenzamide (0.305 mL, 2 mmol), followed by THF (1.7 mL). Chloromagnesium dimethyl-

aminoborohydride (MgAB, 2 mL, 1M, 2 mmol) was then added dropwise via a syringe. The reaction was monitored by TLC (Hex/EtOAc, 1:1). After 30 min, the reaction solution was added dropwise to a solution of acetaldehyde (2 mmol) and acetic acid (2 mmol) in pentane (10 mL). After 15 min, saturated aqueous NH₄Cl (2 mL) was added. The organic layer was separated, and the aqueous phase was extracted with Et₂O (2 × 10 mL). The combined organic layers were washed with 1 M HCl (10 mL), dried with magnesium sulfate, and concentrated under reduced pressure to yield crude aldehyde as an orange oil. To a fritted column was added 25 g of aluminum oxide (basic alumina) in a hexane slurry and covered by a thin layer of sand. The system was flushed with a 1:1 mixture of hexanes:ethyl acetate (solvent). The crude aldehyde was carefully applied to the sand, and more solvent was dispensed. Fractions of 1–2 mL were analyzed via TLC. The combined organic layers were dried over magnesium sulfate and concentrated under reduced pressure to give the aldehyde as a pale yellow oil (0.160 g, 75% yield). For other aldehydes prepared by this method, see Table 6.

Benzaldehyde. Pale yellow oil (0.160 g, 75% yield). ¹H NMR (500 MHz, CDCl₃): δ 10.02 (s, 1H), 7.91–7.86 (m, 2H), 7.66–7.61 (m, 1H), 7.56–7.50 (m, 2H) ppm. ¹³C NMR (125 MHz, CDCl₃): δ 192.6, 136.6, 134.7, 129.9, 129.2 ppm.

Cyclohexanecarboxaldehyde.⁴³ Clear oil (0.146 g, 65% yield). ¹H NMR (500 MHz, CDCl₃): δ 9.55 (s, 1H), 2.21–2.13 (m, 1H), 1.87–1.79 (m, 2H), 1.72–1.63 (m, 2H), 1.62–1.54 (m, 1H), 1.34–1.14 (m, 5H) ppm. ¹³C NMR (125 MHz, CDCl₃): δ 204.9, 50.0, 26.0, 25.9, 25.0 ppm.

4-Phenylbutanal.⁴⁴ Clear oil (0.207 g, 70% yield). ¹H NMR (500 MHz, CDCl₃): δ 9.76 (t, *J* = 1.7 Hz, 1H), 7.33–7.26 (m, 2H), 7.24–7.16 (m, 3H), 2.67 (t, *J* = 7.6 Hz, 2H), 2.49–2.43 (m, 2H), 2.02–1.92 (m, 2H) ppm. ¹³C NMR (125 MHz, CDCl₃): δ 202.5, 141.4, 128.6 (2 carbons), 126.3, 43.3, 35.2, 23.8 ppm.

p-Chlorobenzaldehyde. White solid (0.259 g, 92% yield). ¹H NMR (500 MHz, CDCl₃): δ 9.97 (s, 1H), 7.80 (d, *J* = 6.1 Hz, 2H), 7.49 (d, *J* = 6.2 Hz, 2H) ppm. ¹³C NMR (125 MHz, CDCl₃): δ 191.0, 141.1, 134.9, 131.0, 129.6 ppm.

4-Benzylbenzaldehyde.⁴⁸ Clear oil (0.290 g, 74% yield). ¹H NMR (500 MHz, CDCl₃): δ 9.98 (s, 1H), 7.84–7.79 (m, 2H), 7.38–7.35 (m, 2H), 7.34–7.30 (m, 2H), 7.26–7.22 (m, 1H), 7.21–7.18 (m, 2H), 4.07 (s, 2H) ppm. ¹³C NMR (125 MHz, CDCl₃): δ 192.1, 148.6, 139.9, 134.8, 130.2, 129.7, 129.1, 128.8, 126.6, 42.1 ppm.

3-Bromo-4-methylbenzaldehyde. White solid (0.212 g, 53% yield). ¹H NMR (500 MHz, CDCl₃): δ 9.91 (s, 1H), 8.03 (d, *J* = 1.7 Hz, 1H), 7.71 (dd, *J* = 7.7, 1.7 Hz, 1H), 7.40 (d, *J* = 7.7 Hz, 1H), 2.48 (s, 3H) ppm. ¹³C NMR (125 MHz, CDCl₃): δ 190.6, 145.3, 136.0, 133.5, 131.5, 128.6, 125.8, 23.6 ppm.

p-Methoxybenzaldehyde. Yellow oil (0.164 g, 60% yield). ¹H NMR (500 MHz, CDCl₃): δ 9.88 (s, 1H), 7.83 (d, *J* = 8.8 Hz, 2H), 7.00 (d, *J* = 8.8 Hz, 2H), 3.88 (s, 3H) ppm. ¹³C NMR (125 MHz, CDCl₃): δ 191.0, 164.8, 132.1, 130.1, 114.5, 55.7 ppm.

4-Chloromethylbenzaldehyde.⁴⁹ White solid (0.175 g, 60% yield). ¹H NMR (500 MHz, CDCl₃): δ 10.00 (s, 1H), 7.86 (d, *J* = 8.3 Hz, 2H), 7.54 (d, *J* = 8.3 Hz, 2H), 4.62 (s, 2H) ppm. ¹³C NMR (125 MHz, CDCl₃): δ 191.7, 144.0, 136.3, 130.2, 129.2, 45.4 ppm.

p-Nitrobenzaldehyde. Yellow solid (0.212 g, 70% yield). ¹H NMR (500 MHz, CDCl₃): 10.15 (s, 1H), 8.38 (d, *J* = 8.3 Hz, 2H), 8.07 (d, *J* = 8.3 Hz, 2H) ppm. ¹³C NMR (125 MHz, CDCl₃): δ 190.5, 151.2, 140.2, 130.6, 124.4 ppm.

General Procedure for the Reduction of Amides to Aldehydes with MeLAB, Purified by Bisulfite Adduct Formation. The following procedure for the reduction of *N*-methoxy-*N*-methylbenzamide by MeLAB is representative. To an oven-dried and argon-cooled 25 mL round-bottom flask equipped with a stir bar and septum was added *N*-methoxy-*N*-methylbenzamide (0.305 mL, 2 mmol), followed by THF (1.7 mL). Chloromagnesium dimethylaminoborohydride (MeLAB, 2 mL, 1M, 2 mmol) was then added dropwise via a syringe. The reaction was monitored by TLC (Hex/EtOAc, 1:1). Upon completion, the reaction solution was added dropwise to a solution of acetaldehyde (2 mmol) and acetic acid (2 mmol) in pentane (10 mL). After 15 min, saturated aqueous NH₄Cl

(2 mL) was added. The organic layer was separated, and the aqueous phase was extracted with Et₂O (2 × 10 mL). The combined organic layers were washed with 1 M HCl (10 mL), dried with MgSO₄, and concentrated under reduced pressure to yield crude aldehyde as an orange oil. The crude aldehyde (2 mmol) was transferred to a round-bottom flask equipped with a magnetic stir bar, followed by EtOH (3 mL) and EtOAc (5 mL) and cooled to 0 °C (ice bath). A saturated aqueous solution of NaHSO₃ (1 mL) was added with stirring. After 4 h, the solid bisulfite adduct was isolated by vacuum filtration, washed with Et₂O (3 × 5 mL), and dried under vacuum to yield a white solid. The bisulfite adduct was then added to a round-bottom flask dissolved in H₂O (10 mL), and a 37% formalin solution (2 mL) was added, followed by Et₂O (20 mL). The biphasic solution was stirred for 1 h. The aqueous layer was separated and extracted with a 1:1 mixture of THF/Et₂O (3 × 10 mL). The combined organic layers were dried over magnesium sulfate and concentrated under reduced pressure to give the aldehyde as a pale yellow oil (0.160 g, 75% yield).

Benzaldehyde. Pale yellow oil (0.160 g, 75% yield). ¹H NMR (500 MHz, CDCl₃): δ 10.01 (s, 1H), 7.90–7.84 (m, 2H), 7.65–7.59 (m, 1H), 7.55–7.48 (m, 2H) ppm. ¹³C NMR (500 MHz, CDCl₃): δ 192.6, 136.6, 134.6, 129.9, 129.2 ppm.

■ ASSOCIATED CONTENT

📄 Supporting Information

The Supporting Information is available free of charge on the ACS Publications website at DOI: 10.1021/acs.joc.6b00276.

Copies of ¹¹B, ¹H, and ¹³C NMR spectra and additional spectra for all compounds (PDF)

■ AUTHOR INFORMATION

Corresponding Author

*E-mail: singaram@ucsc.edu.

Notes

The authors declare no competing financial interest.

■ ACKNOWLEDGMENTS

C.L.B. would like to thank Dr. Rebecca Braslau and Dr. Andrew Bockus for helpful discussions.

■ DEDICATION

Dedicated to the memory of Professor Joseph F. Bunnett.

■ REFERENCES

- (1) Brown, R. S. In *The Amide Linkage: Structural Significance in Chemistry, Biochemistry, and Material Science*; Greenberg, A., Breneman, C. M., Liebman, J. F., Eds.; John Wiley & Sons, Inc.: Hoboken, NJ, 2000; pp 85–114.
- (2) Borkar, S. R.; Manjunath, B. N.; Balasubramaniam, S.; Aidhen, I. S. *Carbohydr. Res.* **2012**, *358*, 23–30.
- (3) (a) Wen, J. J.; Crews, C. M. *Tetrahedron: Asymmetry* **1998**, *9*, 1855–1858. (b) Soto-Cairolí, B.; Justo de Pomar, J.; Soderquist, J. A. *Org. Lett.* **2008**, *10*, 333–336.
- (4) Brown, H. C.; Tsukamoto, A. J. *J. Am. Chem. Soc.* **1959**, *81*, 502–503.
- (5) Nahm, S.; Weinreb, S. M. *Tetrahedron Lett.* **1981**, *22*, 3815–3818.
- (6) (a) Krebs, A.; Kaletta, B.; Nickel, W. J.; Rueger, W.; Tikwe, L. *Tetrahedron* **1986**, *42*, 1693–1702. (b) Benoit, G.-E.; Carey, J. S.; Chapman, A. M.; Chima, R.; Hussain, N.; Popkin, M. E.; Roux, G.; Tavassoli, B.; Vaxelaire, C.; Webb, M. R.; Whatrup, D. *Org. Process Res. Dev.* **2008**, *12*, 88–95.
- (7) (a) Kim, S.; Ahn, K. H. *J. Org. Chem.* **1984**, *49*, 1717–1724. (b) Coutts, L. D.; Geiss, W. B.; Gregg, B. T.; Helle, M. A.; King, C.-H. R.; Ito, Z.; Mateo, M. E.; Meckler, H.; Zettler, M. W.; Knutson, J. C. *Org. Process Res. Dev.* **2002**, *6*, 246–255.

- (8) (a) Brown, H. C.; Tsukamoto, A. J. *J. Am. Chem. Soc.* **1964**, *86*, 1089–1095. (b) Ha, J. H.; Ahn, J. H.; An, D. K. *Bull. Korean Chem. Soc.* **2006**, *27*, 121–122. (c) Choi, S.-J.; Lee, K.-J.; Lee, G.-B.; An, D.-K. *Bull. Korean Chem. Soc.* **2008**, *29*, 1407–1408. (d) Mickel, S. J.; Sedelmeier, G. H.; Niederer, D.; Schuerch, F.; Grimler, D.; Koch, G.; Daeffler, R.; Osmani, A.; Hirni, A.; Schaer, K.; Gamboni, R.; Bach, A.; Chaudhary, A.; Chen, S.; Chen, W.; Hu, B.; Jagoe, C. T.; Kim, H.-Y.; Kinder, F. R.; Liu, Y.; Lu, Y.; McKenna, J.; Prashad, M.; Ramsey, T. M.; Repič, O.; Rogers, L.; Shieh, W.-C.; Wang, R.-M.; Waykole, L. *Org. Process Res. Dev.* **2004**, *8*, 101–106. (e) Smith, A. B.; Beauchamp, T. J.; LaMarche, M. J.; Kaufman, M. D.; Qiu, Y.; Arimoto, H.; Jones, D. R.; Kobayashi, K. *J. Am. Chem. Soc.* **2000**, *122*, 8654–8664.
- (9) Hudlicky, M. *Reductions in Organic Chemistry*; Ellis Horwood Limited: Chichester, U.K., 1984; pp 164–171.
- (10) Brown, H. C.; Bigley, D. B.; Arora, S. K.; Yoon, N. M. *J. Am. Chem. Soc.* **1970**, *92*, 7161–7167.
- (11) (a) Wittig, G.; Hornberger, P. *Ann. Chim. (Paris)* **1952**, *577*, 11–15. (b) Staab, H. A.; Braunling, H. *Ann. Chim. (Paris)* **1962**, *654*, 119–130. (c) Brown, H. C.; Tsukamoto, A. J. *J. Am. Chem. Soc.* **1961**, *83*, 2016–2017. (d) Brown, H. C.; Tsukamoto, A. J. *J. Am. Chem. Soc.* **1961**, *83*, 4549–4552.
- (12) Douat, C.; Heitz, A.; Martinez, J.; Fehrentz, J. A. *Tetrahedron Lett.* **2000**, *41*, 37–40.
- (13) (a) Balasubramaniam, S.; Aidhen, I. S. *Synthesis* **2008**, *2008*, 3707–3738. (b) Braun, M.; Waldmuller, D. *Synthesis* **1989**, *1989*, 856–858. (c) Niu, T.; Zhang, W. M.; Huang, D. F.; Xu, C. M.; Wang, H. F.; Hu, Y. L. *Org. Lett.* **2009**, *11*, 4474–4477.
- (14) Williams, J. M.; Jobson, R. B.; Yasuda, N.; Marchesini, G.; Dolling, U.-H.; Grabowski, E. J. *J. Tetrahedron Lett.* **1995**, *36*, 5461–5464.
- (15) Heller, S. T.; Newton, J. N.; Fu, T.; Sarpong, R. *Angew. Chem., Int. Ed.* **2015**, *54*, 9839–9843.
- (16) Davis, F. A.; Gaddiraju, N. V.; Theddu, N.; Hummel, J. R.; Kondaveeti, S. K.; Zdilla, M. J. *J. Org. Chem.* **2012**, *77*, 2345–2359.
- (17) (a) Schedler, D. J. A.; Li, J.; Ganem, B. *J. Org. Chem.* **1996**, *61*, 4115–4119. (b) Bower, S.; Kreutzer, K. A.; Buchwald, S. L. *Angew. Chem., Int. Ed. Engl.* **1996**, *35*, 1515–1516.
- (18) (a) White, J. M.; Tunoori, A. R.; Georg, G. I. *J. Am. Chem. Soc.* **2000**, *122*, 11995–11996. (b) Spletstoser, J. T.; White, J. M.; Georg, G. I. *Tetrahedron Lett.* **2004**, *45*, 2787–2789. (c) Spletstoser, J. T.; White, J. M.; Tunoori, A. R.; Georg, G. I. *J. Am. Chem. Soc.* **2007**, *129*, 3408–3419.
- (19) Kautzner, B.; Wailes, P. C.; Weigold, H. *J. Chem. Soc. D* **1969**, 1105a.
- (20) (a) Wipf, P. *Top. Organomet. Chem.* **2004**, *8*, 1–25. (b) Wipf, P.; Jahn, H. *Tetrahedron* **1996**, *52*, 12853. (c) Zhao, Y.; Snieckus, V. *Org. Lett.* **2014**, *16*, 390–393.
- (21) For a review, see: (a) Fisher, G. B.; Harrison, J.; Fuller, J. C.; Goralski, C. T.; Singaram, B. *Tetrahedron Lett.* **1992**, *33*, 4533–4536. (b) Fuller, J. C.; Stangeland, E. L.; Goralski, C. T.; Singaram, B. *Tetrahedron Lett.* **1993**, *34*, 257–260. (c) Fisher, G. B.; Fuller, J. C.; Harrison, J.; Alvarez, S. G.; Burkhardt, E. R.; Goralski, C. T.; Singaram, B. *J. Org. Chem.* **1994**, *59*, 6378–6385. (d) Harrison, J.; Alvarez, S. G.; Godjoian, G.; Singaram, B. *J. Org. Chem.* **1994**, *59*, 7193–7194. (e) Alvarez, S. G.; Fisher, G. B.; Singaram, B. *Tetrahedron Lett.* **1995**, *36*, 2567–2570. (f) Collins, C. J.; Fisher, G. B.; Reem, A.; Goralski, C. T.; Singaram, B. *Tetrahedron Lett.* **1997**, *38*, 529–532.
- (22) Bailey, C. L.; Murphy, C. L.; Clary, J. W.; Eagon, S.; Gould, N.; Singaram, B. *Heterocycles* **2012**, *86*, 331–341.
- (23) (a) Brown, H. C.; Zweifel, G. *J. Am. Chem. Soc.* **1961**, *83*, 1241–1246. (b) Zweifel, G.; Nagase, K.; Brown, H. C. *J. Am. Chem. Soc.* **1962**, *84*, 190–195. (c) Brown, H. C.; Moerikofer, A. W. *J. Am. Chem. Soc.* **1963**, *85*, 2063–2065. (d) Brown, H. C.; Kebly, K. A. *J. Am. Chem. Soc.* **1964**, *86*, 1795–1801.
- (24) Godjoian, G.; Singaram, B. *Tetrahedron Lett.* **1997**, *38*, 1717–1720.
- (25) Hutchins, R. O.; Learn, K.; El-Telbany, F.; Stercho, Y. P. *J. Org. Chem.* **1984**, *49*, 2438–2443.
- (26) Fisher, G. B.; Fuller, J. C.; Harrison, J.; Goralski, C. T.; Singaram, B. *Tetrahedron Lett.* **1993**, *34*, 1091–1094.
- (27) LiAlH₄: (a) Uffer, H.; Schlittler, E. *Helv. Chim. Acta* **1948**, *31*, 1397–1400. (b) Gaylord, N. G. *Reductions With Complex Metal Hydrides*; Wiley-Interscience: New York, 1956; pp 544–592. (c) Zabicky, J. *The Chemistry of Amides*; Wiley-Interscience: New York, 1970; pp 795–801. Borane: (d) Brown, H. C.; Heim, P. *J. Am. Chem. Soc.* **1964**, *86*, 3566–3567. (e) Brown, H. C.; Heim, P. *J. Org. Chem.* **1973**, *38*, 912–916. (f) Brown, H. C.; Narasimhan, S.; Choi, Y. M. *Synthesis* **1981**, *1981*, 996. NaBH₄: (g) Borch, R. F. *Tetrahedron Lett.* **1968**, *9*, 61–65. (h) Satoh, T.; Suzuki, S.; Suzuki, Y.; Miyaji, Y.; Imai, Z. *Tetrahedron Lett.* **1969**, *10*, 4555–4558. LiEt₃BH: (i) Brown, H. C.; Kim, S. C. *Synthesis* **1977**, *1977*, 635–636.
- (28) Brown, H. C.; Kim, S. C. *Synthesis* **1977**, *1977*, 635–636.
- (29) Winterfeldt, E. *Synthesis* **1975**, *1975*, 617–630.
- (30) Mandal, S. B.; Giri, V. S.; Sabeena, M. S.; Pakrashi, S. C. *J. Org. Chem.* **1988**, *53*, 4236–4241.
- (31) (a) Brown, H. C.; Heim, J. *J. Org. Chem.* **1973**, *38*, 912–916. (b) Kornet, M. J.; Thio, P. A.; Tan, A. S. *J. Org. Chem.* **1968**, *33*, 3637–3639.
- (32) Flaniken, J. M.; Collins, C. J.; Lanz, M.; Singaram, B. *Org. Lett.* **1999**, *1*, 799–801.
- (33) Brown, H. C.; Singaram, B.; Singaram, S. *J. Organomet. Chem.* **1982**, *239*, 43–64.
- (34) Bailey, C. L.; Clary, J. W.; Tansakul, C.; Klabunde, L.; Anderson, C. L.; Joh, A. Y.; Lill, A. T.; Peer, N.; Braslau, R.; Singaram, B. *Tetrahedron Lett.* **2015**, *56*, 706–709.
- (35) Vance, J. R.; Schafer, A.; Robertson, A. P. M.; Lee, K.; Turner, J.; Whittell, G. R.; Manners, I. *J. Am. Chem. Soc.* **2014**, *136*, 3048–3064.
- (36) Taniguchi, T.; Curran, D. P. *Org. Lett.* **2012**, *14*, 4540–4543.
- (37) (a) March, J.; Smith, M. B. *Advanced Organic Chemistry*, 6th ed.; John Wiley & Sons, Inc.: Hoboken, NJ, 2007; p 1281. (b) Seki, M.; Hatsuda, M.; Yoshida, S. *Tetrahedron Lett.* **2004**, *45*, 6579–6581. (c) Kjell, P. D.; Slattery, B. J.; Semo, M. J. *J. Org. Chem.* **1999**, *64*, 5722–5724. (d) Pandit, C. R.; Mani, N. S. *Synthesis* **2009**, *23*, 4032–4036.
- (38) (a) Ehrlich, J.; Bogert, M. T. *J. Org. Chem.* **1947**, *12*, 522–534. (b) Craig, J. C.; Hamon, D. P. *J. Org. Chem.* **1965**, *30*, 4168–4175. (c) Brown, H. C.; Cha, J. S.; Yoon, N. M.; Nazer, B. *J. Org. Chem.* **1987**, *52*, 5400–5406. (d) Faul, M.; Larsen, R.; Levinson, A.; Tedrow, J.; Vounatsos, F. *J. Org. Chem.* **2013**, *78*, 1655–1659.
- (39) Krasovskiy, A.; Knochel, P. *Synthesis* **2006**, *2006*, 0890–0891.
- (40) Chusov, D.; List, B. *Angew. Chem., Int. Ed.* **2014**, *53*, 5199–5201.
- (41) Das, S.; Bobbink, F. D.; Laurenczy, G.; Dyson, P. J. *Angew. Chem., Int. Ed.* **2014**, *53*, 12876–12879.
- (42) Dieskau, A. P.; Begouin, J.-M.; Plietker, B. *Eur. J. Org. Chem.* **2011**, *2011*, 5291–5296.
- (43) Prebil, R.; Stavber, G.; Stavber, S. *Eur. J. Org. Chem.* **2014**, *2014*, 395–402.
- (44) Xu, B.; Lumb, J.-P.; Arndtsen, B. A. *Angew. Chem., Int. Ed.* **2015**, *54*, 4208–4211.
- (45) Jurutka, P. W.; Kaneko, I.; Yang, J.; Bhogal, J. S.; Swierski, J. C.; Tabacaru, C. R.; Montano, L. A.; Huynh, C. C.; Jama, R. A.; Mahelona, R. D.; Sarnowski, J. T.; Marcus, L. M.; Quezada, A.; Lemming, B.; Tedesco, M. A.; Fischer, A. J.; Mohamed, S. A.; Ziller, J. W.; Ma, N.; Gray, G. M.; van der Vaart, A.; Marshall, P. A.; Wagner, C. E. *J. Med. Chem.* **2013**, *56*, 8432–8454.
- (46) Achar, T. K.; Maiti, S.; Mal, P. *RSC Adv.* **2014**, *4*, 12834–12839.
- (47) Kim, B. R.; Lee, H.-G.; Kim, E. J.; Lee, S.-G.; Yoon, Y.-J. *J. Org. Chem.* **2010**, *75*, 484–486.
- (48) Molander, G. A.; Elia, M. D. *J. Org. Chem.* **2006**, *71*, 9198–9202.
- (49) Fiammengo, R.; Musilek, K.; Jäschke, A. *J. Am. Chem. Soc.* **2005**, *127*, 9271–9276.